

Ellison® Pad-It X-Press™ (Assembly)

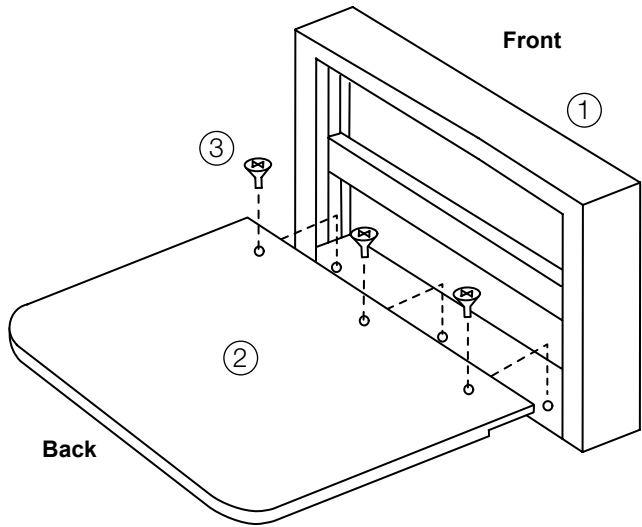

Parts included:

Item:	Qty:
(1) Clamping Frame	1
(2) Plastic Base Plate	1
(3) Fastening Screw	3
(4) Press Bar Knob	1
(5) Press Bar	1
(6) Locking Knob	1

Tools Required :

$\frac{3}{32}$ " Hex Wrench (Included)

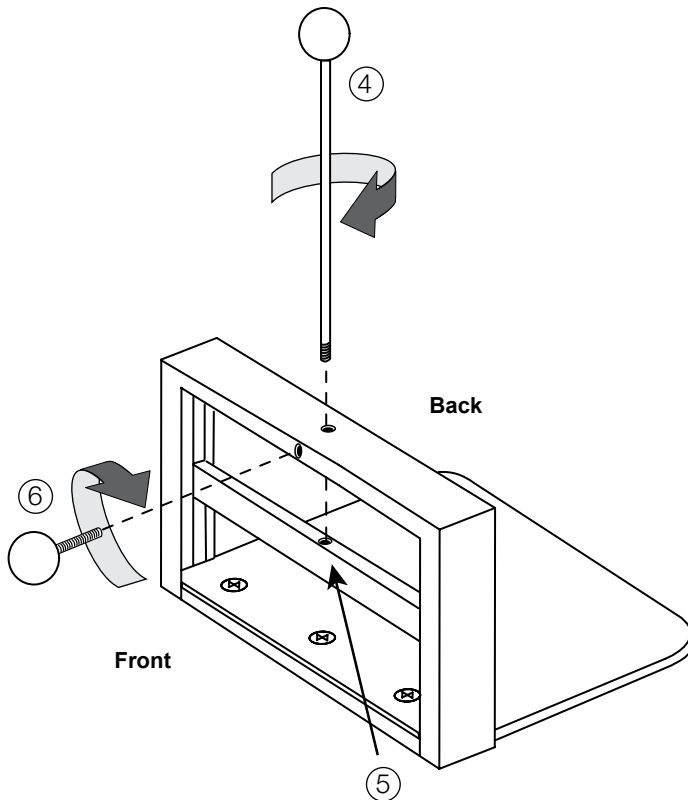

1. Place Base Plate (Item 2) on top of metal strip that connects the side posts of Clamping Frame (Item 1). Be sure recessed lip on bottom of Base Plate is snug against the metal Frame.
2. Using the supplied Hex Wrench, secure the Base Plate (Item 2) to the metal Clamping Frame (Item 1) with Fastening Screws (Item 3). Screws go through the Base Plate and into the metal strip of the Frame.
3. Slide the Press Bar Knob (Item 4) through hole in the top of the Clamping Frame, making sure it aligns with the threaded hole in the Press Bar (Item 5). Carefully screw the Press Bar Knob shaft into the Press Bar (do not over tighten). Thread the Locking Knob (Item 6) into the hole in the front of the Clamping Frame.

Continued

Using Ellison® Pad-It X-Press™

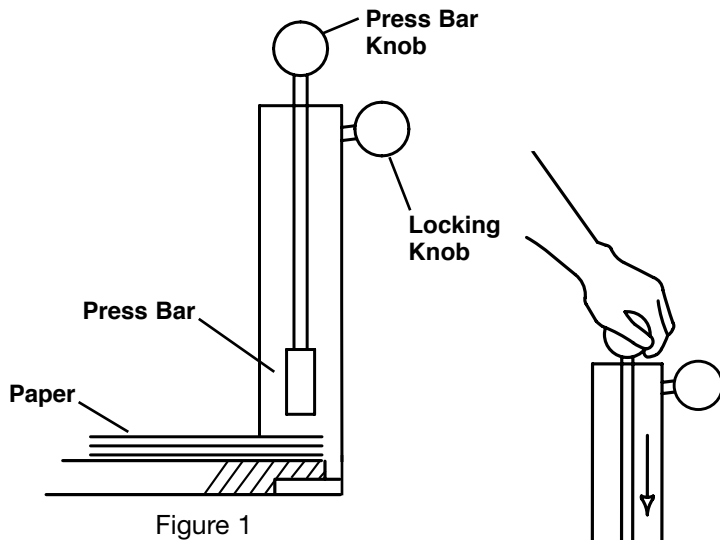

4. Place stack of paper to be padded under the Press Bar so the edge that will receive the Padding Compound is aligned with the front edge of the Press Bar. Multiple pads may be stacked on top of one another or side by side (Figure 1).

5. Push down on the Press Bar Knob until the Press Bar touches the stack of paper to be padded. Do not press too hard as this may cause the paper to "fan" or spread apart. Too much pressure can also crease the top sheets (Figure 2).

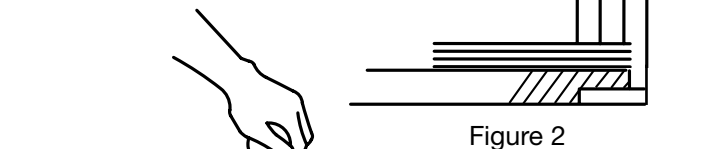

6. Before removing your hand from the Press Bar Knob, tighten the Locking Knob at the front of the Press. Do not over tighten Locking Knob (Figure 3).

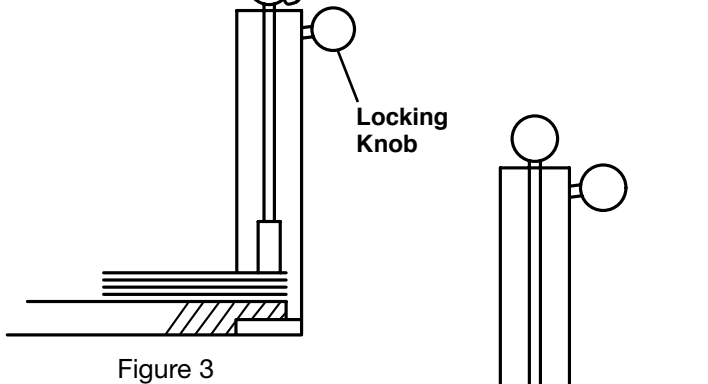

7. Apply Padding Compound with a brush to the edges of the paper clamped in the Press. Either apply one thicker coat, or 2-3 thinner coats, allowing Compound to dry for ½-1 hour between coats. After Compound dries, release Locking Knob and raise Press Bar to remove pads. If multiple pads are stacked on top of each other, let them dry completely before cutting them apart with a utility knife (Figure 4).

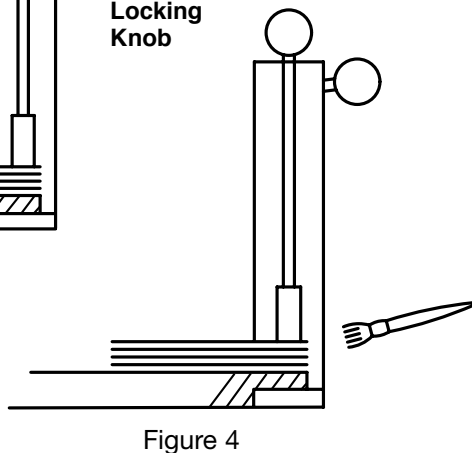

17187 Ellison Pad-It X-Press